



# Better Buried Closures

## Instructions

## Contents:

1.0	General .....	3
2.0	Kit Contents.....	3
3.0	Closure Selection Guide.....	4
4.0	LHS End Cap Installation.....	5
5.0	Cable Preparations.....	5
6.0	Cable Assembly .....	7
7.0	Closure Reentry .....	7
8.0	Closure Extension.....	8
9.0	Adding Service Wires (2" – 5", 50 mm – 125 mm Closures) .....	8

## 1.0 General

1.1 The 3M™ Better Buried Closures are rigid body splice closures designed for direct burial. When filled with a reenterable encapsulating compound, the closure can be reentered for splice rework.

## 2.0 Kit Contents

2.1 The kit contents are shown below:

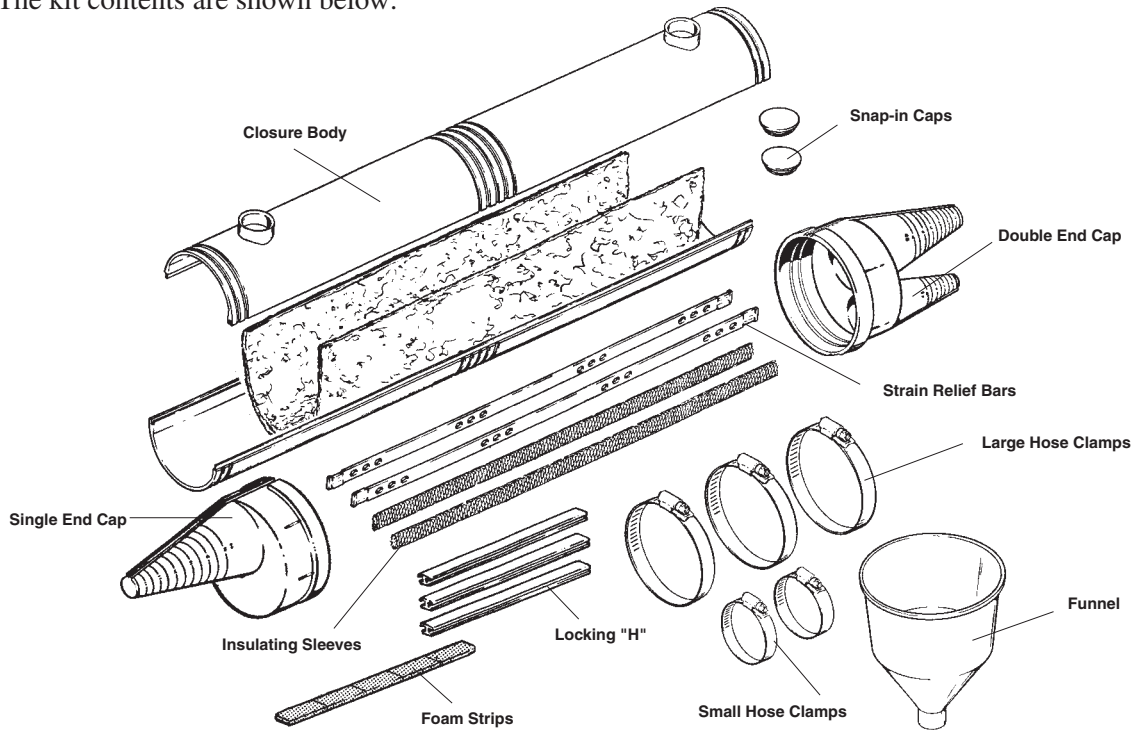

883656

Visually inspect all components. If any component is missing or appears damaged, do not install and call 3M Customer Service at 1-800-426-8688 for a replacement product.

2.2 The following materials are included in each 3M™ Better Buried Closure Kit:

Kit Components	B.B. SB/2SC 2" - 5" (50mm-127mm)	B.B. SB/SC,DC 2" - 5" (50mm-127mm)	B.B. SB/2DC 6" - 9" (152mm-229mm)	B.B. SB/DC,TC 7" - 9" (178mm-229mm)	B.B. Sleeve Kit 2" - 9" (50mm-229mm)
Closure Body	1	1	1	1	1
End Cap, Single (SC)	2	1			
End Cap, Multiple (DC) (TC)		1	2	2	
Spacer Web (SW)	1	1	1	1	1
Strain Relief Bar (SB)	1 or 2	1 or 2	2	2	
Hose Clamps, Closure	3	3	3	3	3
Hose Clamps, Strain Bar	2	2	2	2	
Funnel	1	1	1	1	1
Snap-In Cap	2	2	2	2	2
Locking "H"	2	3 or 4	4	5	
Foam Strips	1	1	1	1	

2.3 Additional Materials Required (Dependent on Kit Contents):

- Shield Connectors
- Encapsulating Compound (permanent or reenterable)
- 3M™ Scotchcast™ Spacer Web 4430 (for reentry only)
- Sheath Scuff Material
- Pair Saver
- 3M™ Scotchcast Strain Relief Bar Kits 4465 or 4465-L
- Moisture Resistant Splicing Connectors
- Better Buried End Caps (bulk)
- Better Buried Sleeve Kits (Closure Extension)
- Hose Clamps
- Vinyl Tape
- DR Tape
- Scotch® Linerless Rubber Splicing Tape 130C
- Scotch® Vinyl Mastic Tape
- B Sealing Tape
- Bonding Braid

### 3.0 Closure Selection Guide

3.1 Select proper closure using the following tables.

#### 3.2 Maximum Splice Bundle Capacities (Straight Splice)

Connector	2" x 12" 50 x 305mm	2" x 24" 50 x 610mm	3" x 24" 76 x 610mm	4" x 24" 102 x 610mm	5" x 26" 127 x 660mm	6" x 26" 152 x 660mm	7" x 26" 178 x 660mm	9" x 26" 229 x 660mm
<b>3M™ MS2™ Splicing Module 4000-DWP</b>	50 pair 0.5 mm (24 AWG) UY Only	100 pair 0.5 mm (24 AWG)	200 pair 0.5 mm (24 AWG)	400 pair 0.5 mm (24 AWG)	600 pair 0.5 mm (24 AWG)	900 pair 0.5 mm (24 AWG)	1200 pair 0.5 mm (24 AWG)	2400 pair 0.4 mm (24 AWG)
<b>3M™ Scotchlok™ Connectors UR (w/ 3" pigtails)</b>	25 pair 0.6 mm (22 AWG)	50 pair 0.6 mm (22 AWG)	100 pair 0.6 mm (22 AWG)	200 pair 0.6 mm (22 AWG)	300 pair 0.6 mm (22 AWG)	400 pair 0.6 mm (22 AWG)	600 pair 0.6 mm (22 AWG)	900 pair 0.6 mm (22 AWG)

#### 3.3 Closure Dimension Guide

Closure End Cap Port Diameters					Maximum Splice Openings			Approx. Amount of Comp. Required (Ave. Splice)
Closure Size	Single Entry (Max.)	Multiple Entry (Max.)			Single Sheath	Double Sheath		
		1	2	3		Outer	Inner	
<b>2" x 12"</b> (50 x 305 mm)	1.2" 30 mm	1.2" 30 mm	0.7" 18 mm	-	5" 127 mm	-	-	21 oz. 600 gms
<b>2" x 24"</b> (50 x 610 mm)	1.2" 30 mm	1.2" 30 mm	0.7" 18 mm	-	17" 432 mm	17" 432 mm	14" 356 mm	42 oz. 1200 gms
<b>3" x 24"</b> (76 x 610 mm)	1.6" 41 mm	1.6" 41 mm	1.0" 25 mm	-	17" 432 mm	17" 432 mm	14" 356 mm	106 oz. 3000 gms
<b>4" x 24"</b> (102 x 610 mm)	2.0" 51 mm	2.0" 51 mm	1.5" 38 mm	-	17" 432 mm	17" 432 mm	14" 356 mm	159 oz. 4500 gms
<b>5" x 26"</b> (127 x 660 mm)	2.4" 61 mm	2.4" 61 mm	1.8" 46 mm	-	19" 483 mm	19" 483 mm	16" 406 mm	254 oz. 7200 gms
<b>6" x 26"</b> (152 x 660 mm)	3.3" 84 mm	2.7" 68 mm	2.0" 50 mm	1.5 40 mm	19" 483 mm	19" 483 mm	16" 406 mm	441 oz. 12500 gms
<b>7" x 26"</b> (178 x 660 mm)	3.5" 89 mm	3.5" 89 mm	2.2" 56 mm	2.2 56 mm	19" 483 mm	19" 483 mm	16" 406 mm	530 oz. 15000 gms
<b>9" x 26"</b> (229 x 660 mm)	4.0" 102 mm	4.0" 102 mm	2.5" 64 mm	2.5 64 mm	19" 483 mm	19" 483 mm	16" 406 mm	742 oz. 21000 gms

Note: All metric conversions are approximate.

## 4.0 LHS End Cap Installation

### 4.1 End Cap Installation on Cut Cables Procedure:

- Select desired port(s).
- Cut off cone(s) as close as possible to the diameter of the cable using the cut guides on either side of the cone(s). See cable diameter tape on back cover.

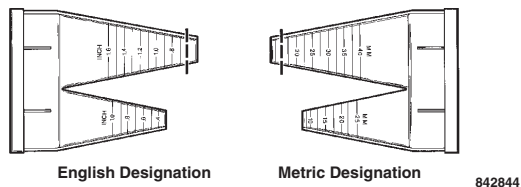

- When not slitting cap, place piece of foam in each slot on inside of cap.

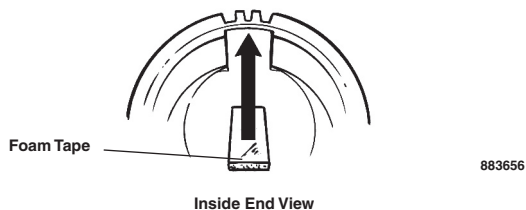

- Push cable through port and slide end cap down cable so not to interfere with cable preparations or splicing.

**DO NOT SLIT END CAP UNLESS INSTALLING ON EXISTING CABLE.**

### 4.2 End Cap Installation on Straight Through or Express Cable Procedure:

- Select desired port(s).
- Cut off cone(s) as close as possible to the diameter of the cable using the cut guides on the cone(s). See cable diameter tape on back cover.
- Slit end cap between raised guide rails.

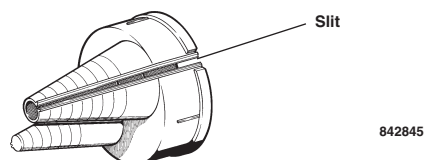

- Place cap around cable.
- Slide locking "H" Strip into place over the raised guide rails. Start at the large (body) end and work towards the small end of the cone. Cut "H" Strip to length.

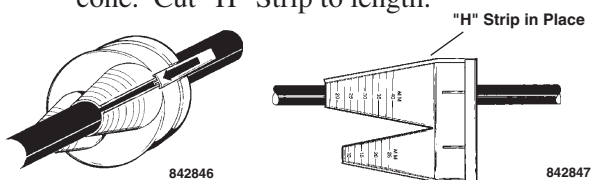

- Slide end cap down so not to interfere with cable preparations or splicing.

## 5.0 Cable Preparations

- Position and secure cables according to the splice opening for the closure size selected. See closure dimension guide for the maximum splice openings.

- Scuff 6" (152 mm) of outer sheaths as shown.

- Wrap all scuffed areas with vinyl tape.

**Note:** *Vinyl tape should be removed from under Shield Bond Connectors when installed.*

- Remove outer sheath for a splice opening no greater than the maximum splice opening listed for closure size in closure dimension guide.

- Remove shield flush with outer sheath.

- Clean filled cable for good encapsulant adhesion and sealing.

### 5.7 Single Sheath Cables Procedure:

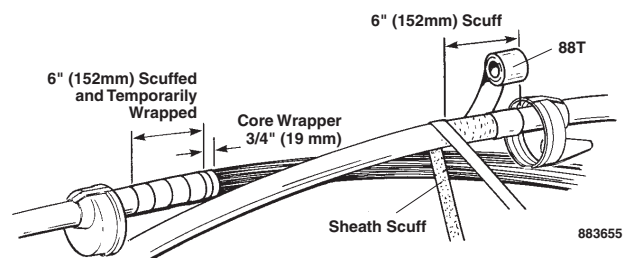

- Insert base assemblies of shield connectors between the core wrapper and the shield 180° apart. Insert base assemblies of shield connectors between the core wrapper and the shield 180° apart. Install first nut and torque to 45 ± 5 in-lbs (5.2 ± 0.6 kg·m).

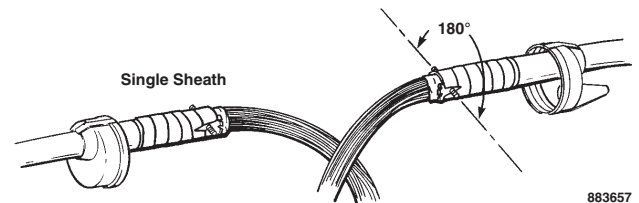

**Note:** *Use only 1 (one) sheath connector on each cable for the 2" (50 mm) diameter closures.*

- Trim core wrapper, leaving 3/4" (19 mm).
- Install insulation sleeve on strain relief bar(s). Trim length if necessary to clear mounting holes.
- Install one strain relief bar on Shield Bond Connectors (to hold splice opening and provide temporary bond.)

**Note:** *Branch cables should be bonded according to illustrations. If necessary, shield connector studs may be trimmed to clear cover halves of smaller diameter closures.*

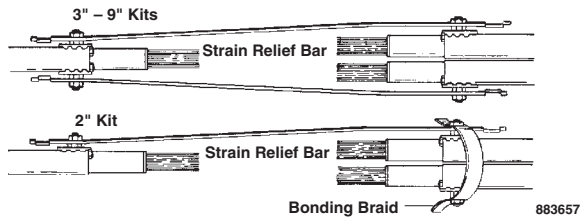

- e. Splice conductors per standard procedure.
- f. To insure thorough encapsulation of conductors, do not tightly bind the splice bundle.
- g. Install second bond bar if required.
- h. Remove vinyl tape from scuffed sheaths. Keep these areas clean during the following bonding and sealing collar construction operations.
- i. Build outer sheath sealing collars just beyond ends of strain relief bar(s). Sealing collars are one wrap of 3/4" (19 mm) B sealing tape. Completely overwrap with highly stretched DR tape (white side out.)

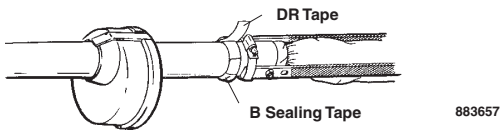

- j. Install hose clamps over ends of strain relief bar(s).
- Note:** *Rotate hose clamps so heads will not obstruct fill ports on body.*
- k. Overwrap strain relief hose clamps with DR tape to keep hose clamps tails from flagging.

**5.8 Double Sheath Cables Procedure:**

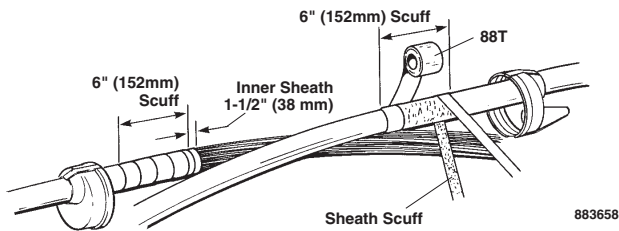

- a. Remove outer sheath and shield for a splice opening no greater than the maximum splice opening listed for closure size in closure dimension guide.
  - b. Scuff 6" (152 mm) of outer sheath.
  - c. Wrap scuffed sheath with vinyl tape.
- Note:** *Vinyl Tape should be removed from under Shield Bond Connector when installed.*
- d. Scuff 2" (51 mm) of inner sheath.
  - e. Remove inner sheath, except for 1-1/2" (38 mm) at both ends of splice opening.

- f. Insert base assemblies of the shield connectors between the inner sheath and the shield, 180° apart. Insert base assemblies of shield connectors between the core wrapper and the shield 180° apart. Install first nut and torque to 45 ± 5 in-lbs (5.2 ± 0.6 kg·m).

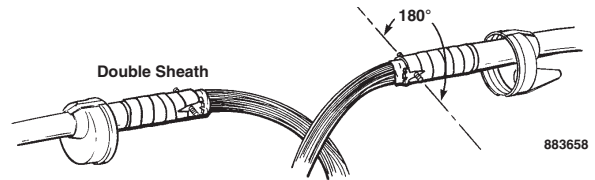

**Note:** *Use only 1 (one) shield connector on each cable for 2" (51 mm) diameter closures.*

- g. Build inner sheath sealing collars on exposed inner sheaths. Sealing collars are one wrap of 3/4" (19 mm) B sealing tape completely overwrapped with highly stretched DR tape (white side out).
- h. Cover inner sheath sealing collars with vinyl tape to protect them from contamination of grease and dirt.
- i. Remove core wrap even with inner sheath.
- j. Install insulation sleeve on strain relief bar(s). Trim to length if necessary to clear mounting holes.
- k. Install one strain relief bar on 3M™ Scotchlok™ Shield Bond Connectors (to hold splice opening and provide temporary bond).

**Note:** *Branch cables should be bonded according to illustrations. If necessary, shield connector studs may be trimmed to clear cover halves of smaller diameter closures.*

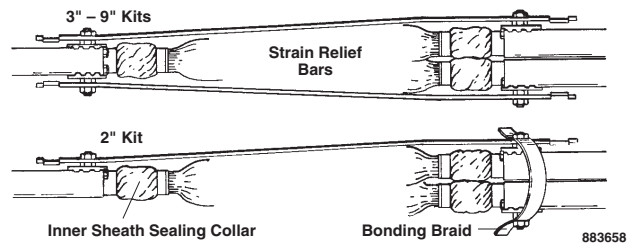

- l. Splice conductors per standard procedure.
- m. To insure thorough encapsulating compound penetration, do not tightly bind the splice bundle.
- n. Remove Scotch® Vinyl Tape 88T from scuffed sheath(s) and inner sheath sealing collars. Keep these areas clean during the following bonding and sealing collar construction operations.

- o. Install second bond bar if required.
- p. Install hose clamps over ends of strain relief bars.

**Note:** *Rotate hose clamps so heads will not obstruct fill ports on body.*

- q. Overwrap the strain relief hose clamps with DR tape to prevent hose clamp tails from flagging.
- r. Build outer sheath sealing collars just beyond ends of strain relief bars. Outer sheath sealing collars are one (1) wrap of 3/4" (19 mm) B sealing tape completely overwrapped with highly stretched DR tape (white side out).

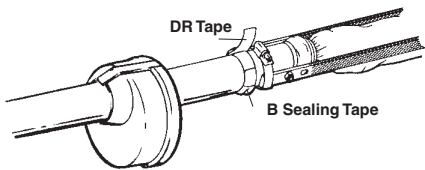

883659

## 6.0 Closure Assembly

**Note:** *Make sure all vinyl tape has been removed from splice encapsulation area.*

- 6.1 Center lower closure half on splice bundle and attach upper half (upper half has fill ports) mating the tongue and groove.

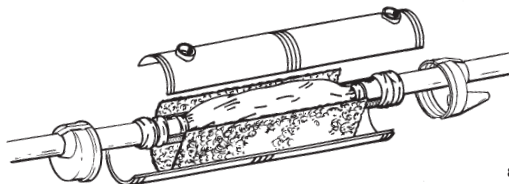

883659

- 6.2 Place one large hose clamp around center of closure and tighten.
- 6.3 Set end caps in grooves on closure body ends and secure with large hose clamps. Seal end caps to cable sheaths with 2 half-lapped layers of vinyl tape. Start the half-lap layers on the cable and tape up the cone.

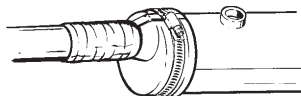

883659

- 6.4 Position closure for burial on firmly packed earth. Avoid sharp bends or kinks in the cable.
- 6.5 Slightly incline one closure end about 1/2" (13 mm). Properly place supports under the closure for compound filling.
- 6.6 Insert funnel into lower closure fill port. (During filling, air will escape from higher end.)

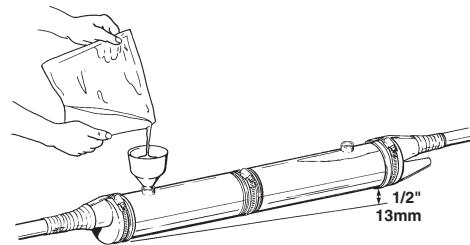

883660

- 6.7 Mix compound according to instructions.

**Note:** *Carefully follow health, safety and environmental information on product label or Material Data Sheet for encapsulating compound being used.*

- 6.8 Position closure in final position to be buried, then fill closure with compound. Continue mixing and pouring compound until closure is completely filled and trapped air is removed.
- 6.9 Close fill ports with the snap-in caps.
- 6.10 Check for any compound leaks. If leaks are observed, tighten hose clamps and retape as required.
- 6.11 Closure can be buried immediately.

## 7.0 Closure Reentry

- 7.1 Remove hose clamps from closure and end caps. Remove any tape from end caps.
- 7.2 With a twisting motion, pull end caps from closure and slide down cable.
- 7.3 Grasping closure at one end, slowly separate halves from encapsulant.
- 7.4 Remove spacer web from splice and discard. **DO NOT REUSE THIS SPACER WEB.**
- 7.5 Tear cured encapsulant away, as necessary, to access splice.
- 7.6 After completion of repair, place 3M™ Scotchcast™ Spacer Web 4430 around splice and reassemble closure as outlined in Section 6.1 - 6.3. End caps and sleeves can be reused.

**Note:** *If original end caps are reused, place a small piece of B-sealing tape in slots on inside of caps.*

**Note:** *Be sure that the spacer web 4430 does not block the fill ports.*

- 7.7 Fill closure with new compound as outlined in Sections 6.4 - 6.11.

DIA. INCHES TO 100THS.

## 8.0 Closure Extension

- 8.1 Cut a closure body in half using a cable saw or similar tool. Cut grooves are provided on closure bodies.
- 8.2 Assemble the closure by staggering the cut sections. Position hose clamps. Tape seams with LR tape or vinyl tape.

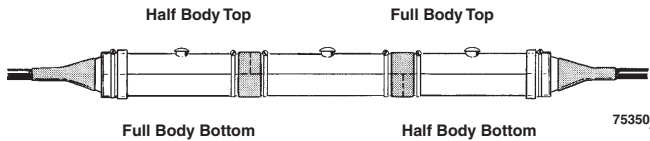

- 8.3 Fill closure with compound as outlined in Sections 6.4 - 6.11.

## 9.0 Adding Service Wires (2" - 5", 50mm - 125mm Closures)

- 9.1 Cut a small "+" pattern through the service wire port.

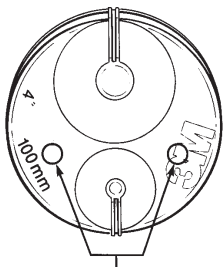

- 9.2 Force service wire through port.

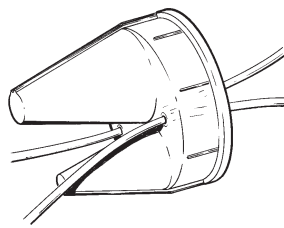

- 9.3 Scuff service wire sheath that will be located inside closure. Build a sealing collar on each service wire. Service wire collars are one wrap of 3/4" B sealing tape completely overwrapped with highly stretched DR tape (white side out). Align the service wire sealing collars directly over the outer sheath sealing collars on main cable.

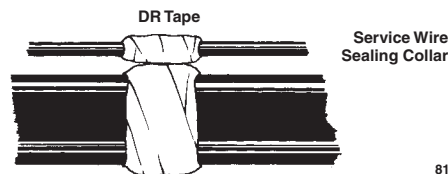

- 9.4 Bond per standard procedure.
- 9.5 Install end cap. (See Section 4). Tighten hose clamps.
- 9.6 Complete closure assembly per Sections 5 and 6.

3M, Scotchcast, Scotchlok and MS<sup>2</sup> are trademarks of 3M Company.

### Important Notice

All statements, technical information, and recommendations related to 3M's products are based on information believed to be reliable, but the accuracy or completeness is not guaranteed. Before using this product, you must evaluate it and determine if it is suitable for your intended application. You assume all risks and liability associated with such use. Any statements related to the product which are not contained in 3M's current publications, or any contrary statements contained on your purchase order shall have no force or effect unless expressly agreed upon, in writing, by an authorized officer of 3M.

### Warranty; Limited Remedy; Limited Liability.

This product will be free from defects in material and manufacture for a period of one (1) year from the time of purchase. **3M MAKES NO OTHER WARRANTIES INCLUDING, BUT NOT LIMITED TO, ANY IMPLIED WARRANTY OF MERCHANTABILITY OR FITNESS FOR A PARTICULAR PURPOSE.** If this product is defective within the warranty period stated above, your exclusive remedy shall be, at 3M's option, to replace or repair the 3M product or refund the purchase price of the 3M product. **Except where prohibited by law, 3M will not be liable for any indirect, special, incidental or consequential loss or damage arising from this 3M product, regardless of the legal theory asserted.**



Communication Markets Division  
3M Telecommunications

6801 River Place Blvd.  
Austin, TX 78726-9000  
800.426.8688  
Fax 800.626.0329  
www.3MTelecommunications.com



Recycled paper  
40% Pre-consumer waste paper  
10% Post-consumer waste paper

Litho in USA  
© 3M 2006 78-8135-4353-1-A